

Massachusetts Institute of Technology
Electromechanical Systems Group

Electronics First: DIGITAL LOGIC GATES - THE INVERTER

Board and Circuit Schematic:

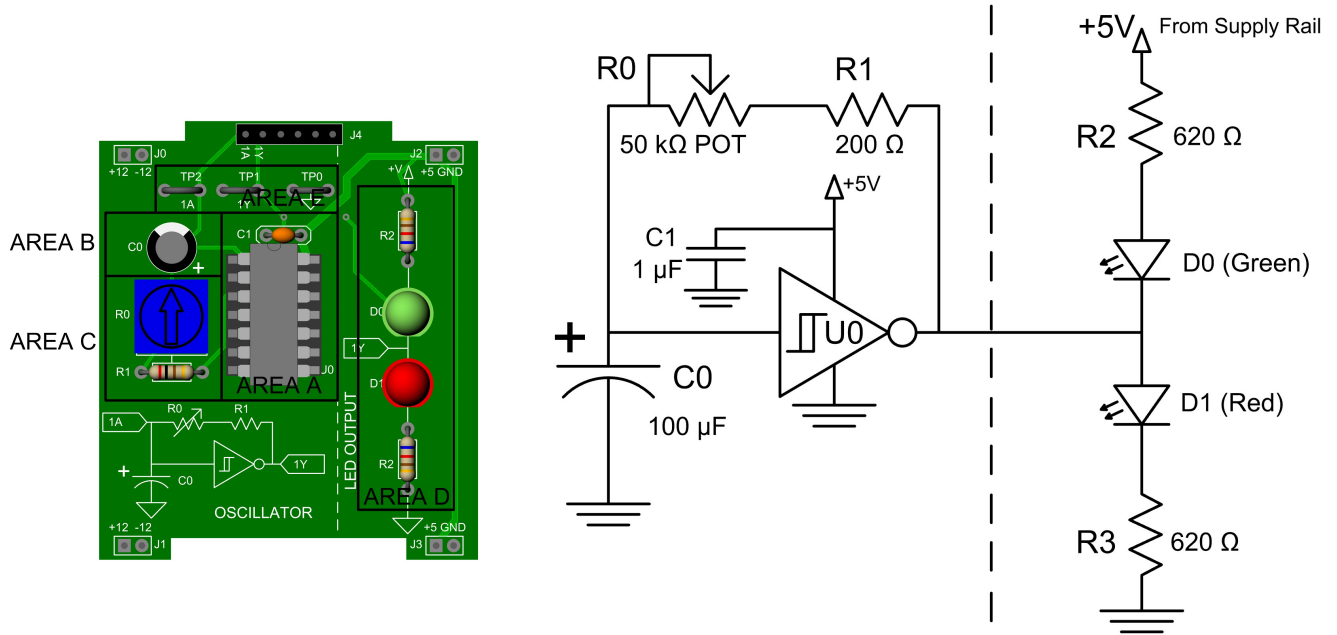

Materials:

Part	Quantity	Part Number	Vendor
Breadboard	1	377-2646-ND	DigiKey
Breadboard Power Supply and Power Cable	1	-	-
Multimeter	1	MN35-ND	DigiKey
6-pin Header Pins	1	609-3263-ND	DigiKey
2-pin Rail Connector Pins	4	952-2262-ND	DigiKey
Soldering Iron and Solder Wire	1 ea	T0052918199N-ND	DigiKey
620 Ω Resistors	2	CF14JT620RCT-ND	DigiKey
200 Ω Resistor	1	CF14JT200RCT-ND	DigiKey
Potentiometer	1	3386P-503TLF-ND	DigiKey
Red LED	1	1080-1597-1-ND	DigiKey
Green LED	1	754-1263-ND	DigiKey
Aluminum Electrolytic Capacitor	1	1189-1300-ND	DigiKey
Ceramic Capacitor	1	399-13923-1-ND	DigiKey
Schmitt Trigger	1	296-1577-5-ND	Texas Instruments/Digikey
14 Pin DIP Socket	1	AE9989-ND	Digikey

The Build:

Analog signals or waveforms can assume a continuum or range of values. Digital signals are a “special case” of analog signals. We interpret digital signals as having discrete values or levels. Digital waveforms are commonly *quantized* to two levels. A signal is interpreted as being either *high* or *low*. Quantization can make it easier to recover the information in a digital signal when noise is present. We create and interpret digital signals using special circuits called *logic gates*. Logic gates are the foundation of modern digital computers. This build bridges the analog and digital worlds with the construction of an oscillator that can serve as a *clock*, a component that provides timing for dynamic digital systems like a computer. Here, the clock alternately flashes two LEDs.

DIGITAL CIRCUITS are the foundation of modern computing. The "information" that digital circuits process is binary. This means that binary digital waveforms are interpreted as having only two possible valid voltage states: *high* or *low*. We might decide, for example, that any voltage between 4 and 5 volts represents a logical *high* or *1* or *true* and any voltage between 0 and 1 volts represents a logical *low* or *0* or *false*. Other voltages, in between the *high* and *low* voltage ranges, are undefined. The voltage bands used to define the *high* and *low* ranges make the digital interpretation of a signal more reliable even when some noise is present. A waveform with an unwanted wiggle or oscillation that causes the voltage to move, for example, between 4.2 volts and 4.8 volts, can still be interpreted crisply as a *high* signal in our example.

High and *low* voltage states can represent numbers or the status of a light (on or off) or a door (open or closed) or an alarm. Digital values are processed by circuit components called *logic gates*. Some common logic gates include the **AND**, **NAND**, **OR**, **NOR**, and **NOT** gates. Each gate executes a specific logical or "boolean" math function. For instance, an AND gate might process two digital inputs, *A* and *B*, and produce one output. The output of an AND gate is *high* only when both the *A* and *B* inputs are *high*. If one or both of the inputs are *low*, the output will be *low*. Think of it like a doorknob with two keyholes - you need both keys to unlock the door. If you have only one or none of the keys, the door remains locked.

There are a wide variety of logic gates, each performing a different logical operation. More complicated situations than our "two-key door" might require multiple logic gates used in conjunction with one another, possibly with more than two inputs per gate. In this lab, we use a single logic gate to produce a square wave with an adjustable frequency that can serve as a digital clock. The clock is like a digital metronome.

Theory of Operation and Predictions

BEFORE WE BUILD AND TEST THE CLOCK BOARD, let's understand how the circuit operates. You will be constructing an *RC relaxation oscillator*. The "RC" indicates that at least one resistor and one capacitor are combined with an inverter to create an oscillator circuit that generates a periodic signal.

Inverters

The oscillator circuit uses a NOT gate, or *inverter*. This gate is designed to produce an output voltage (V_{out}) that is the digital opposite of the input voltage (V_{in}). We will use this gate to produce an output signal called a "square wave," which alternates between states.

A simple inverter has an internal reference voltage (V_{ref}) or threshold against which it evaluates an input voltage V_{in} . When V_{in} is greater than V_{ref} , the input

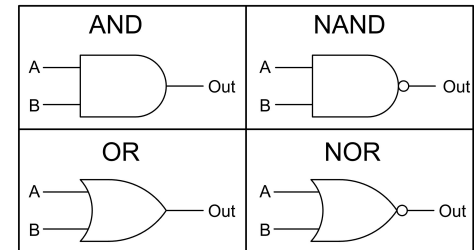

Example Logic Gates

Inputs		Outputs			
A	B	AND	NAND	OR	NOR
0	0	0	1	0	1
0	1	0	1	1	0
1	0	0	1	1	0
1	1	1	0	1	0

Example Logic Gates Truth Table

INVERTER

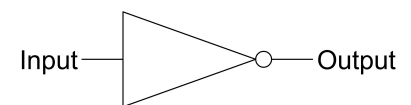

Input	Output
0	1
1	0

Inverter Truth Table

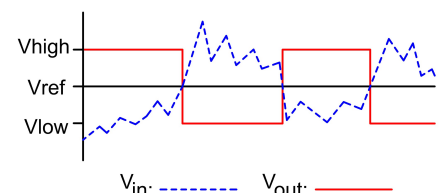

Inverter Input and Output

is considered "high" (V_{high}), and the output V_{out} will be "low" (V_{low}). When V_{in} is less than V_{ref} , the input is read as V_{low} , and the output is V_{high} . A potential weakness of the simple inverter appears when the input signal voltage is not a clear "high" or "low," instead hovering around V_{ref} with noise present. In this case, the inverter may give an indecisive output, rapidly swinging between high and low outputs as the input wiggles around the value V_{ref} .

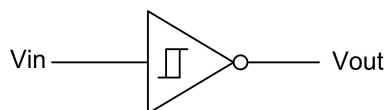

Schmitt Trigger Inverter Symbol

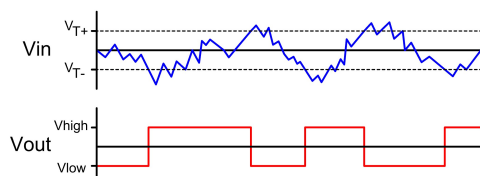

Schmitt Trigger Inverter Input and Output

Schmitt Trigger Inverter

To improve the decisiveness of the inverter's operation, we might employ a special inverter with *hysteresis*. An inverter with hysteresis has not one but rather **two** thresholds, for example, thresholds at 2 volts (V_{T-}) and 3 volts (V_{T+}). This special inverter will only create a low output when the input exceeds the high threshold of 3 volts. It will only create a high output when the input falls below the low threshold of 2 volts. The region in between 2 and 3 volts is a "no man's land." Input voltages in this range cause the inverter to make no change to its output. The input must rise above the high threshold or fall below the low threshold for the output to change. The hope with this type of inverter is that some amount of noise or wiggling in the input signal will be smaller than the range between the two thresholds, and the output will remain decisively at one level until the input is clearly above or below one of the thresholds. One type of inverter with hysteresis is called a **Schmitt trigger**. The 74HC14 hex Schmitt trigger inverter used in this build has preset internal thresholds set during manufacture.

Oscillators and Clocks

Oscillators are electronic circuits that produce a periodic waveform, like a sine wave, square wave, or sawtooth wave. Clocks are typically square wave oscillators. Electronic clocks coordinate timing within a digital circuit. Much like the pendulum of a grandfather clock or the arm of a metronome, clocks operate by shifting output state back and forth with a regular periodicity that can be used to measure time. In the digital world, a clock produces a signal that repetitively alternates between states. A hysteretic inverter like the Schmitt trigger can be used to make a clock.

The consistent beat of the square wave can be used to coordinate the flow of bits of information through digital circuits. Data appears at the output of digital gates and is examined at the inputs of other gates in a computer. A clock can be used to coordinate the sequential processing of information from one set of gates to the next. Here, we will use a clock to make a pair of LED lights flash on and off in sequence.

The clock for this build is sometimes called an *RC relaxation oscillator*. An RC relaxation oscillator uses feedback to cause the Schmitt trigger to oscillate. How does this work?

The key to understanding the oscillator is to remember that the inverter's

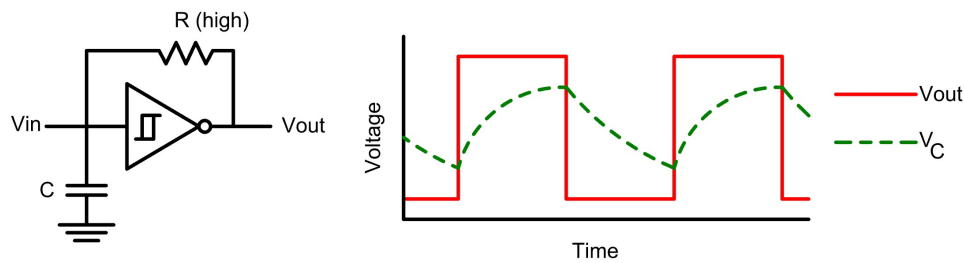

RC Relaxation Oscillator Circuit with High Resistance

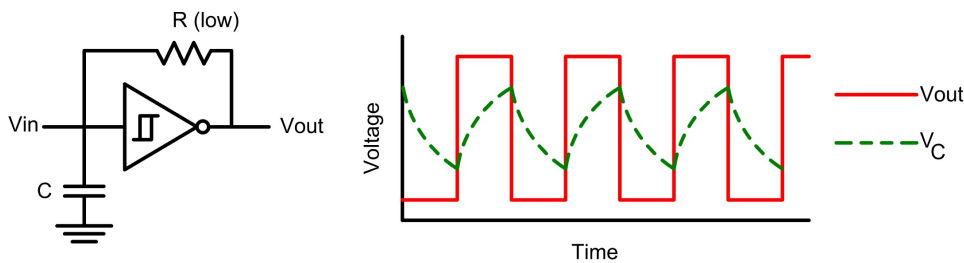

RC Relaxation Oscillator Circuit with Low Resistance

output voltage state is always the opposite of the input voltage digital state. If the input is *high*, the output is *low*, and vice versa. The capacitor connected to the input pin of the Schmitt trigger is analogous to a bucket of water. It holds the voltage at some value, and only changes as the “bucket” is gradually either “filled” or “drained” through some resistance. The feedback resistor, connected between the input and the output pins, is analogous to a “spigot” or “drain” that controls the rate of filling or emptying of the “bucket”. When the capacitor is discharged below the low threshold, the output is high and current flows through the feedback resistor, charging the capacitor (“fills the bucket”). When the capacitor is relatively charged and above the high threshold, the output of the inverter is low. In this case, the capacitor discharges through the resistor (“drains the bucket”). Because the inverter has an output state opposite the input state, the inverter is always dynamically moving its input and output to the opposite of the current state. For this reason, the circuit is sometimes called an “astable” multivibrator, an oscillator with no stable states. The rate of charging and discharging for the capacitor can be controlled by adjusting the values of the capacitor or the resistor. Increasing the capacitance gives a larger “bucket” that takes longer to charge or “fill”. Increasing the resistance lowers the charging current, and again lengthens the time for the capacitor to charge or “fill”.

1.) Given the circuit components you have to build the full RC relaxation oscillator, what will be the most convenient way to change the output frequency?

To consider: Why is a Schmitt trigger more useful than a conventional inverter (with no hysteresis) for making a relaxation oscillator? If we tried to make an RC relaxation oscillator with an inverter with no hysteresis in a noiseless



Prediction 1

environment, how would it behave? Also, note that the Schmitt trigger RC oscillator gives **two** potentially useful waveforms: a digital square wave at the output, and an analog waveform that looks a little like a triangle wave at the input.

LED Flashing

When constructed, **AREA D** of your circuit board will contain one red LED, one green LED, and two resistors (R_2 and R_3) connected between 5V and ground:

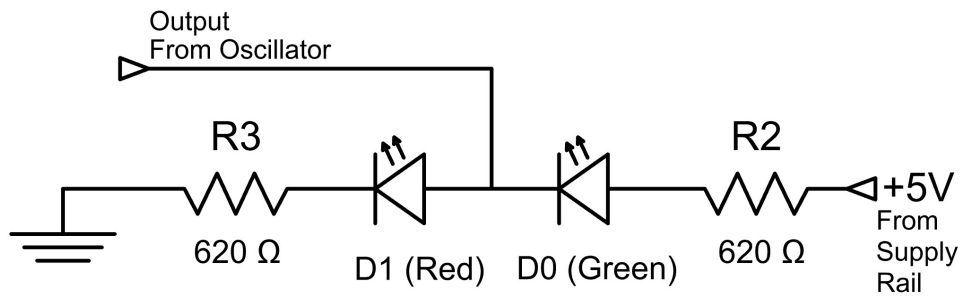

LED Circuit Schematic

The oscillator output is connected directly in between the two LEDs. When the oscillator output V_{out} is high, current flows through the red LED, but not the green LED. This turns the red LED on and leaves the green LED off. When V_{out} is low, there is insufficient voltage to force a current through the red LED, turning it off. However there is now a large enough voltage difference across the green LED to turn it on. This cycle repeats, flashing the LEDs.

- 2.) If you wanted to decrease the speed at which the lights flashed, would you increase or decrease the resistance setting of the potentiometer on your PCB?
- 3.) The manufacturer's datasheet for the 74HC14 Schmitt inverter offers the following equation for the frequency of an RC relaxation oscillator:

$$f \approx \frac{1}{RC \ln \frac{V_{T+}(V_{CC}-V_{T-})}{V_{T-}(V_{CC}-V_{T+})}} \tag{1}$$

In this equation, f is the output frequency, R is the total resistance of the feedback resistor ($R = R_0 + R_1$), C is the value of the timing capacitor, V_{T-} and V_{T+} are the threshold voltages, and V_{CC} is the common collector voltage, which in our case is the voltage provided by the supply rail.

The datasheet states that a V_{CC} of 4.5V yields a positive-going threshold voltage (V_{T+}) of 2.7V, and a negative-going threshold voltage (V_{T-}) of 1.8V. Note that, on the clock board you will build, the feedback resistor is implemented as a potentiometer in series with a fixed resistor. What purpose does the fixed resistor serve? Assume your potentiometer is set to give a total feedback resistance of 25 kΩ. What do you predict the frequency, f , of the flashing lights to be?

Increase Decrease
Circle one

Prediction 2

f:

Prediction 3

Assembly

THIS BUILD INTRODUCES NEW COMPONENTS. Central to the function of this board are two varieties of capacitor and a hex Schmitt trigger inverter in a dual-in-line pin (DIP) integrated circuit (IC) package. To keep track of your progress during construction, the board has been divided into separate areas. See the cover page for a diagram of these areas.

Inverter Socket Installation

Install the 14-pin DIP socket in **AREA A**. Orient the socket correctly. Ensure that the semi-circular notch at the top of the socket lines up with the corresponding notch illustrated on the board.

AREA A has two rows of seven contact points. Press the 14 socket wire leads through the corresponding contact points on the board. Make good solder connections between each of the 14 socket pins and the metal board contacts located on the underside of the circuit board. Be careful to avoid “bridging” or shorting the socket pins together with an excessive blob of solder.

Header and Rail Pin Installation

Install the 6-pin header into pads **J4** at the top of your board. These will facilitate testing later. Insert the pins into the pads and make soldered joints on the underside of the board.

Next, install the rail connector pins into pads **J0, J1, J2, and J3**. These are installed in the reverse direction, with the base of the pin on the underside of the board, and the location of the soldered joint on the top of the board. *BEFORE SOLDERING*, insert the bottom of the pins into your breadboard, and *then* make your soldered connections on the circuit board to ensure proper alignment.

Capacitor Installation

Add the bypass capacitor in **AREA A**. This capacitor effectively “smooths out” the input voltage and protects the 74HC14 from any irregularities in the power supply. Insert the leads of your ceramic capacitor into the two contacts for **C₁** directly above the socket. Pull the leads through until the capacitor is raised just off the surface of the board. Solder the pads beneath the board, and when your joints have cooled, trim any excess wire. *Save your trimmed pieces of wire - you will use them to construct board clips later.*

Now add the timing capacitor in **AREA B**. Install the aluminum electrolytic capacitor into the area containing a circle inscribing two contact points. *Polarity is critical.* Position your capacitor so that the side with the negative pin (marked with a negative sign and white stripe on the body) faces away from the “+”

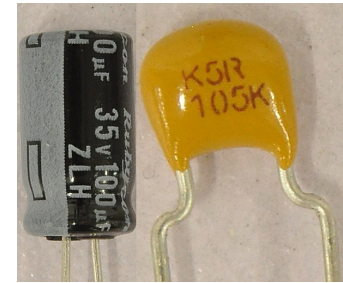

Electrolytic Capacitor (Timing, left)
Ceramic Capacitor (Bypass, right)

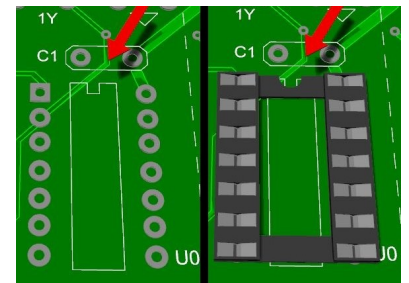

74HC14 Socket Location

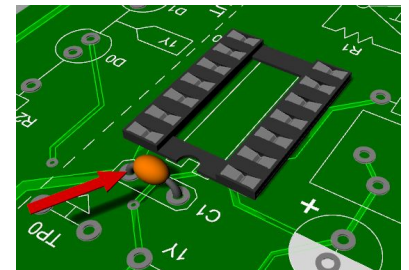

Bypass Capacitor Location

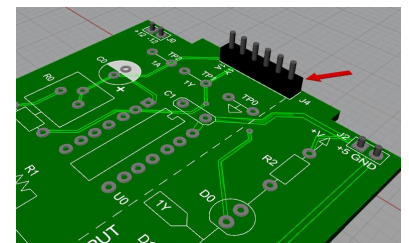

Header Pin Installation

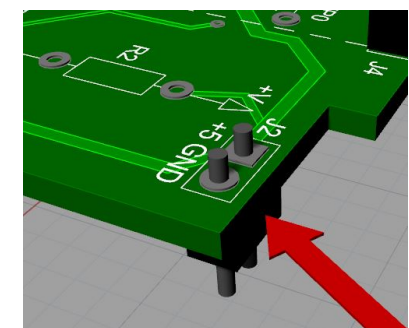

Rail Connector Pin Installation

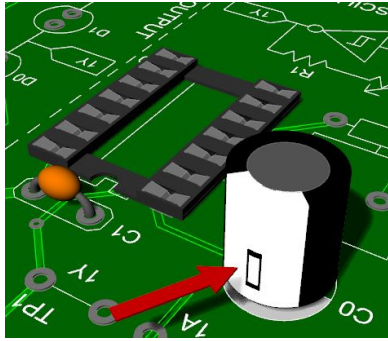

Timing Capacitor Location

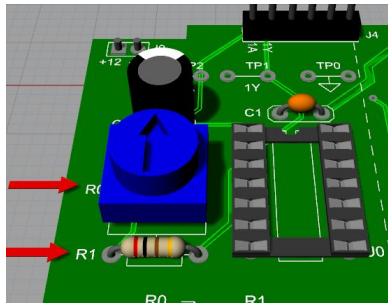

Variable Timing Resistor Positioning

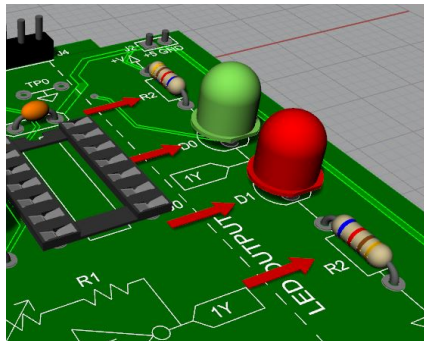

LED Circuit Construction

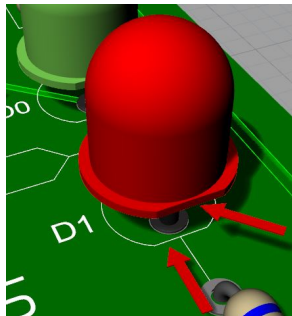

LED Orientation - align the flat side of the LED to the flat side of the circle

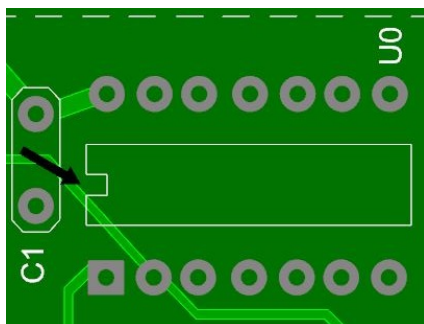

74HC14 Inverter Location

symbol on the PCB. See the picture on the cover to make sure you understand the correct orientation. Solder connections beneath the board.

Variable Timing Resistor Construction

Construct the variable timing resistor in **AREA C**. Install the blue, rotating knob potentiometer into the section labeled for R_0 . Ensure its three triangular-positioned leads are aligned with the three corresponding points of contact. Using the resistor band color code, identify and install your $200\ \Omega$ resistor into the slot labeled for R_1 . Make soldered connections.

LED Output Circuit Construction

Construct the Light Emitting Diode (LED) circuit in **AREA D**. This portion consists of four components: one green LED, one red LED, and two $620\ \Omega$ resistors.

Begin by installing the green LED into the section labeled for D_0 . The direction of its *positioning is critical!* This component is polarized, meaning it illuminates only when a current passes through it in the correct direction. The flat side of the bulb lines up with the shorter of its two lead wires. This is the negative side of the LED. The round side of the bulb lines up with the longer of the two wires. This is the positive side. The LED must be inserted so that current is flowing *from the positive side (longer leg) to the negative side (shorter leg)* for it to work correctly. Align the “flat” side of the LED to the “flat” side of the silk screen circle when you insert the component.

Pull the leads of the LED through the solder pad holes. When the LED is inserted correctly (check repeatedly!), solder joints on the solder pads on the back of the board. Now repeat this process to install the red LED into D_1 . Solder your $620\ \Omega$ resistors into the sections for R_2 and R_3 .

Test Points

Construct the test points in **AREA E**. Take one of the wire cuttings you saved earlier, bend it into an arc, and insert each end into the contact points in pads **TP0**. Trim the length of the wire as necessary. Make soldered joints on the bottom of the board. This is a ground clip.

Repeat this process for sections **TP2** and **TP1**. These test points connect directly to points **1A** and **1Y**, respectively. Refer to the board diagram on the cover to locate these points on the circuit schematic. Test point **1A** is at the input of the 74HC14 hex inverter and **1Y** is the output.

74HC14 Installation

Once all of your soldered joints are completely cooled, install the 74HC14 hex inverter into the socket. *Orientation matters!* Ensure that the notch on the top side of the 74HC14 body aligns with the indent shown on the board.

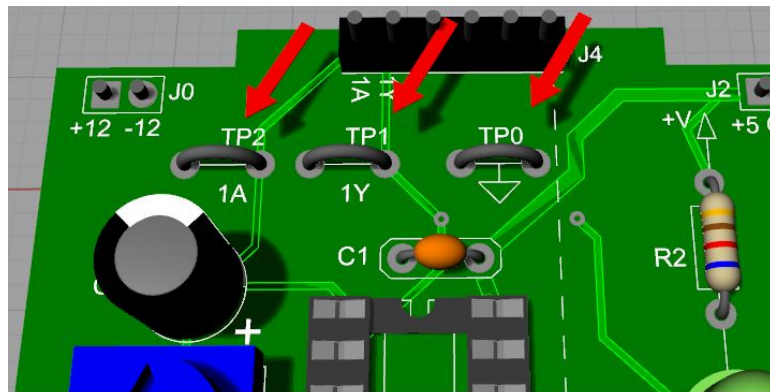

Test Point Soldering Locations

Testing

Carefully connect your circuit board to the breadboard in-line with the power supply module. Ensure that your power cord is properly fitted into the power port you are using on the power supply module. Ensure that the pins of both boards are fully inserted into the breadboard contact holes. If all is well, you can now power up the power supply board. Check that its indicator lights are illuminated. You should see the LED's on the clock board flashing.

LED Circuit

- 1.) Rotate the knob of your potentiometer until it is fully turned counter-clockwise, indicating the highest resistance. Observe the flashing LEDs. Now turn the knob completely in the clockwise direction. Observe the LEDs. If you wanted to decrease the speed at which the lights flashed, would you increase or decrease the resistance value of the potentiometer? Does this concur with your prediction?
- 2.) Rotate the knob of your potentiometer until it is approximately at the halfway point. This is a 50 k Ω potentiometer, so your resistance should now be 25 k Ω . Count how many times the lights flash back and forth in a 10 second period. Frequency is a measure of cycles per second, so what was your observed frequency? Does this concur with your prediction?

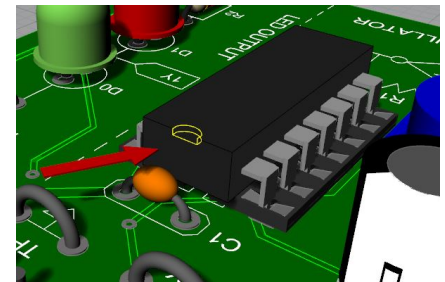

74HC14 Inverter Orientation

Increase Decrease

Circle one

Test 1 - Check against Prediction 2

f:

Test 2 - Check against Prediction 3